

VENTILADORES ALTA PRESIÓN

HIGH PRESSURE FANS

VENTILATEURS HAUTE PRESSION

HOCHDRUCK-RADIALVENTILATOREN

AAZVM

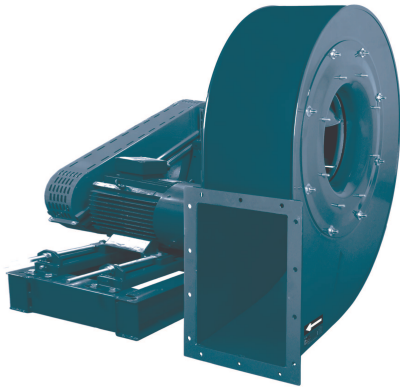

ES

CARACTERÍSTICAS GENERALES:

Serie compuesta por 12 tamaños distintos desde el 350 hasta el 1.250. Caudales desde 2.900 m³/h hasta 65.000 m³/h. Temperatura máxima de trabajo de 130°C en continuo. Presiones estáticas hasta 2.150 mmca.

CARACTERÍSTICAS CONSTRUCTIVAS:

- Carcasa fabricada en chapa de acero laminado.
- Carcasa totalmente soldada.
- Turbina de alabes curvados hacia atrás (a reacción) de simple aspiración y alto rendimiento, fabricada en chapa de acero laminado y recubierta contra la corrosión en polvo de resina epoxy.
- El ventilador se suministrará en ejecución Standard a "EJE LIBRE", es decir sin motor, poleas ni correas.
- Protegidos contra la corrosión mediante recubrimiento en polvo de resina epoxy.

APLICACIONES:

- Diseñados para montaje en tubería están indicados básicamente para:
 - Transportes neumáticos.
 - Inyección de aire en quemadores, hornos...
 - Procesos industriales, extracción localizada, enfriamiento de máquinas.
 - Transporte de aire limpio o ligeramente polvoriento.

BAJO DEMANDA:

- Ventiladores completos que incluyen: motor, poleas, correas, protector de correas y de eje. Montados sobre bancada general.
- Ventiladores antideflagrantes o antiexplosivo con motor certificado ATEX.
- Ventilador preparado para 250°C, 300°C o 450°C.
- Ventiladores fabricados en chapa galvanizada en caliente o acero inoxidable.

EN

GENERAL FEATURES:

Range with 12 sizes from the 350 until the 1.250. Air-flow from 2.900 m³/h until 65.000 m³/h. Maximum air working temperature 130°C in continuous. Static pressures until 2.150 mmwg.

MANUFACTURING FEATURES:

- Rolled steel sheet housing.
- Fully welded housing.
- High efficiency single inlet backward curved impeller, manufactured of rolled steel sheet and epoxy powder finishing.
- The fan as standard will be supplied at "FREE SHAFT", it means without motor, pulleys and belts.
- Epoxy powder coat finishing.

APPLICATIONS:

- Specially designed for duct assembly, are suitable for:
 - Pneumatic transports.
 - Air injection in burners, ovens...
 - Smoke exhaust.
 - Industrial processes.
 - Clean air and light dusty air transport.

UNDER REQUEST:

- Full equipped fans including: motor, pulleys, belts, belts guard and shaft guard. Fitted over a base plate.
- Flameproof or explosionproof fans with ATEX certificated motors.
- Fan for air working temperatures up to 250°C, 300°C and 450°C.
- Hot dip galvanised or stainless steel fans.

ACCESORIOS

ANCILLARIES

ACCESSOIRES

ZUBEHÖR



RFS



ASD



INT



PE



RA



EA



EI



BA



SIL-C



RH

FR

CARACTÉRISTIQUES GÉNÉRALES:

Série composée par 12 tailles de la 350 à la 1.250. Débits de 2.900 m³/h à 65.000 m³/h. Température maximale de l'air 130°C en continu. Pressions statiques jusqu'à 2.150mmce.

CARACTÉRISTIQUES DE FABRICATION:

- Carcasse en tôle d'acier laminé.
- Turbine à réaction d'hautes rendement en tôle d'acier laminé.
- Livré sans moteur et sans transmission.
- Protégés contre la corrosion avec peinture epoxy.

APPLICATIONS:

- Conçus pour montage en gaine.
- Procèdes industriels extraction localisée, refroidissement de machines.
- Injection d'air en brûleurs, fours, jacuzzis...
- Transport d'air propre ou légèrement poussiéreux.
- Transport pneumatique.

OPTIONS DISPONIBLES:

- Montage complet avec moteur et transmission.
- Ventilateur anti-étincelles avec moteur anti-déflagrant ou anti-explosif certifié ATEX.
- Ventilateur pour travailler jusqu'à 250°C, 300°C et 450°C en continu.
- Ventilateurs en tôle galvanisée ou acier inoxydable.

DE

ALLGEMEINE MERKMALE:

Baureihe bestehend aus 12 verschiedenen Größen, von 350 bis 1.250. Luftfördermenge 2.900 m³/h bis 65.000 m³/h. Maximale Arbeitstemperatur von 130 °C im Dauerbetrieb. Statische Drücke bis zu 2.150 mm Wassersäule.

BAULICHE MERKMALE:

- Gehäuse hergestellt aus Walzstahlblech.
- Komplett geschweißtes Gehäuse.
- Mehrschaufel-Hochleistungsturbine mit nach hinten (Reaktionsturbine) geneigten Schaufelrädern mit einfacher Ansaugung, Ausführung in Walzstahlblech und durch eine Pulverbeschichtung aus Epoxidharz vor Korrosion geschützt.
- Der Ventilator wird in der Standardausführung mit „FREIER WELLE“ geliefert, also ohne Motor, Riemenscheiben und Riemen.
- Dank Pulverbeschichtung mit Epoxidharz vor Korrosion geschützt.

ANWENDUNGEN:

- Grundlegende Anwendungsbereiche dieser für den Rohreinbau gedachten Lüfter sind:
 - Drucklufttransporte.
 - Luftzufuhr bei Brennern, Öfen...
 - Industrielle Verfahren, örtliche Absaugung, Maschinenabkühlung.
 - Transport von sauberer oder leicht staubhaltiger Luft.

AUF ANFRAGE:

- Vollständige Ventilatoren mit: motor, Riemenscheiben, Riemen, Riemenschutz und Welle. Montiert auf einem allgemeinen Maschinenbett.
- Explosionsgeschützte oder flammensichere Lüfter mit Motor mit ATEX-Zertifikat.
- Ventilator ausgelegt für 250 °C, 300 °C oder 450 °C.
- Ventilatoren hergestellt aus feuerverzinktem Blech oder rostfreiem Edelstahl.

VENTILADORES ALTA PRESIÓN HIGH PRESSURE FANS VENTILATEURS HAUTE PRESSION HOCHDRUCK-RADIALVENTILATOREN

AAZVM

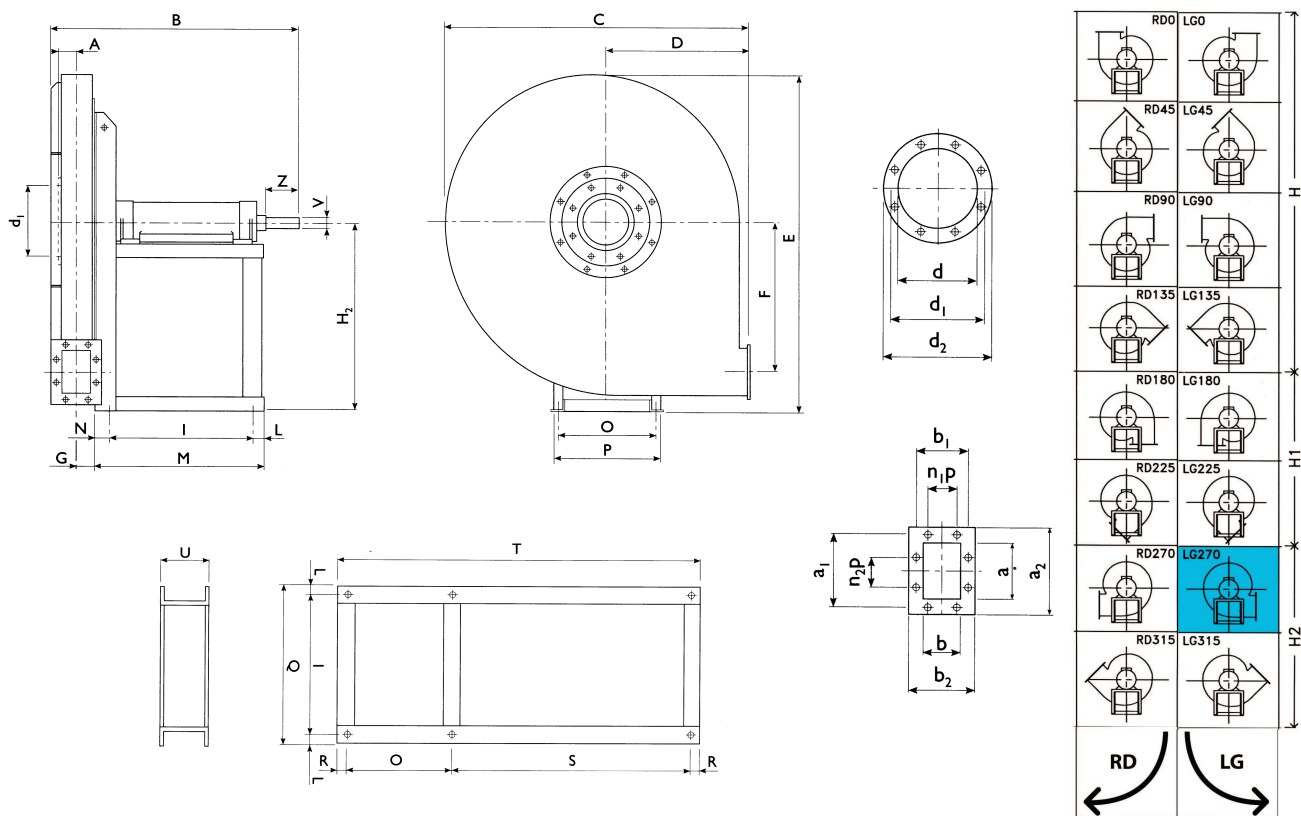

DIMENSIONES / DIMENSIONS / ENCOMBREMENT / ABMESSUNGEN (mm)

Model	A	B	C	D	E	F	G	H	H1	H2	d	d1	d2	n°	Ø	a	b	a1
AAZVM 350	65	555	535	250	615	215	56	355	250	355	185	219	250	8	8	146	105	182
AAZVM 400	71	710	590	280	658	238	63	375	280	375	205	241	275	8	8	166	117	200
AAZVM 450	78	745	645	300	715	265	70	400	300	400	228	265	298	8	8	185	131	219
AAZVM 500	86	765	715	335	795	297	78	450	335	450	255	292	325	8	10	207	148	241
AAZVM 560	95	885	805	375	890	337	89	500	375	500	285	332	365	8	10	231	166	265
AAZVM 630	105	905	910	425	1000	381	99	560	425	560	320	366	400	8	10	258	185	292
AAZVM 710	115	1020	1015	475	1122	426	108	550	475	630	360	405	440	8	10	288	205	332
AAZVM 800	127	1045	1140	530	1265	481	122	620	530	710	405	448	485	12	10	322	229	366
AAZVM 900	140	1190	1285	600	1428	542	136	695	600	800	455	497	535	12	10	361	256	405
AAZVM 1000	160	1445	1430	670	1590	607	152	770	670	900	505	551	585	12	10	404	288	448
AAZVM 1120	185	1480	1600	750	1770	684	169	860	750	1000	565	629	665	12	10	453	322	497
AAZVM 1250	200	1695	1785	840	1983	765	189	960	840	1120	635	698	735	12	12	507	361	551

Model	b1	a2	b2	n1xp	n2xp	n°	Ø	I	L	M	N	O	P	Q	R	S	T	U	Ø
AAZVM 350	139	216	175	-	1x112	6	12	284	23	347	40	288	324	330	18	576	900	100	12
AAZVM 400	151	236	187	-	1x112	6	12	407	28	485	50	355	400	463	22,5	660	1060	120	14
AAZVM 450	165	255	201	-	1x112	6	12	407	28	485	50	355	400	463	22,5	660	1060	120	14
AAZVM 500	182	277	218	1x112	1x112	8	12	407	28	485	50	355	400	463	22,5	780	1180	120	14
AAZVM 560	200	301	236	1x112	1x112	8	12	477	33	560	50	364	418	543	27	832	1250	160	17
AAZVM 630	219	328	255	1x112	2x112	10	12	477	33	560	50	364	418	543	27	832	1250	160	17
AAZVM 710	249	368	285	1x125	2x125	10	12	-	-	650	60	-	590	-	-	-	-	-	-
AAZVM 800	273	402	309	1x125	2x125	10	12	-	-	650	60	-	590	-	-	-	-	-	-
AAZVM 900	300	441	336	1x125	2x125	10	12	-	-	707	55	-	735	-	-	-	-	-	-
AAZVM 1000	332	484	368	2x125	3x125	14	12	-	-	935	100	-	960	-	-	-	-	-	-
AAZVM 1120	366	533	402	2x125	3x125	14	12	-	-	935	100	-	960	-	-	-	-	-	-
AAZVM 1250	405	587	441	2x125	3x125	14	12	-	-	1102	120	-	1060	-	-	-	-	-	-

VENTILADORES ALTA PRESIÓN
HIGH PRESSURE FANS
VENTILATEURS HAUTE PRESSION
HOCHDRUCK-RADIALVENTILATOREN

AAZVM

Model	R.P.M max.	CV	m ³ /h	Ps (mm H ₂ O)
AAZVM 350	5.000	5,5	2.900	700
AAZVM 400	4.750	10	4.000	850
AAZVM 450	4.500	10	5.000	900
AAZVM 500	4.250	20	7.000	1.100
AAZVM 560	4.000	25	9.000	1.100
AAZVM 630	3.750	50	13.500	1.400
AAZVM 710	3.550	60	16.000	1.400
AAZVM 800	3.350	100	22.000	1.700
AAZVM 900	3.150	125	30.000	1.750
AAZVM 1000	3.000	220	40.000	2.150
AAZVM 1120	2.800	270	50.000	2.150
AAZVM 1250	2.500	340	65.000	2.150

AAZVM 350

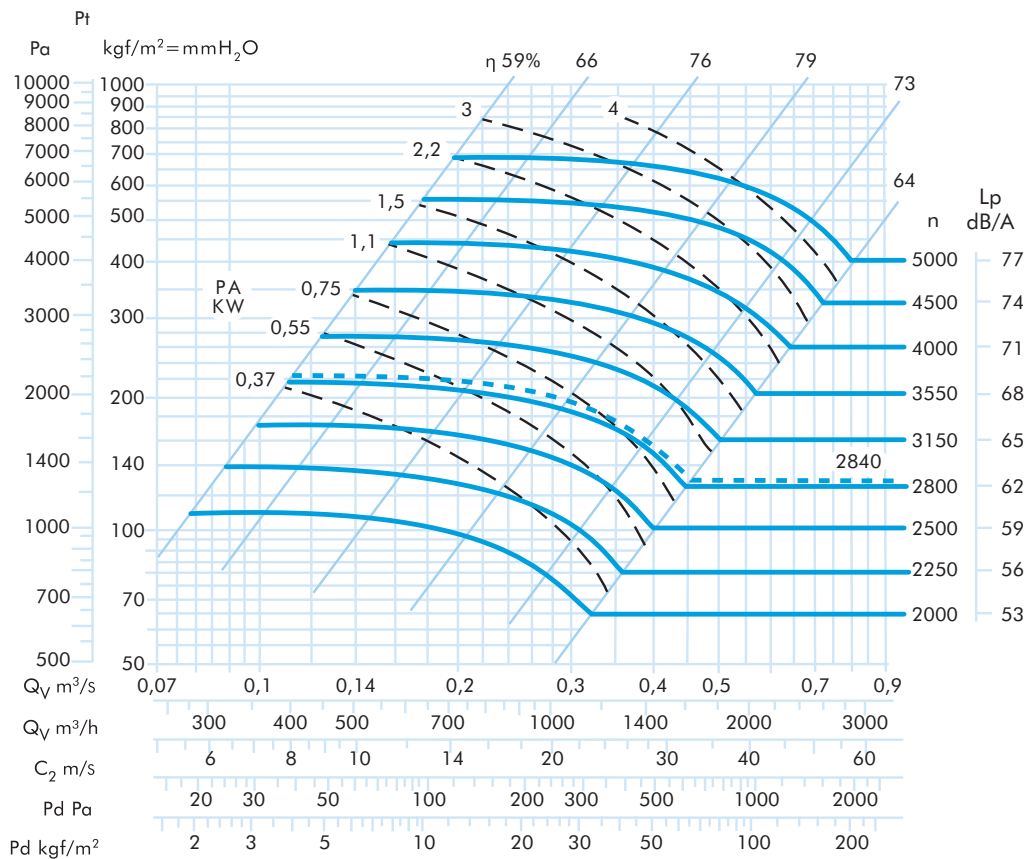

VENTILADORES ALTA PRESIÓN
HIGH PRESSURE FANS
VENTILATEURS HAUTE PRESSION
HOCHDRUCK-RADIALVENTILATOREN

AAZVM

AAZVM 400

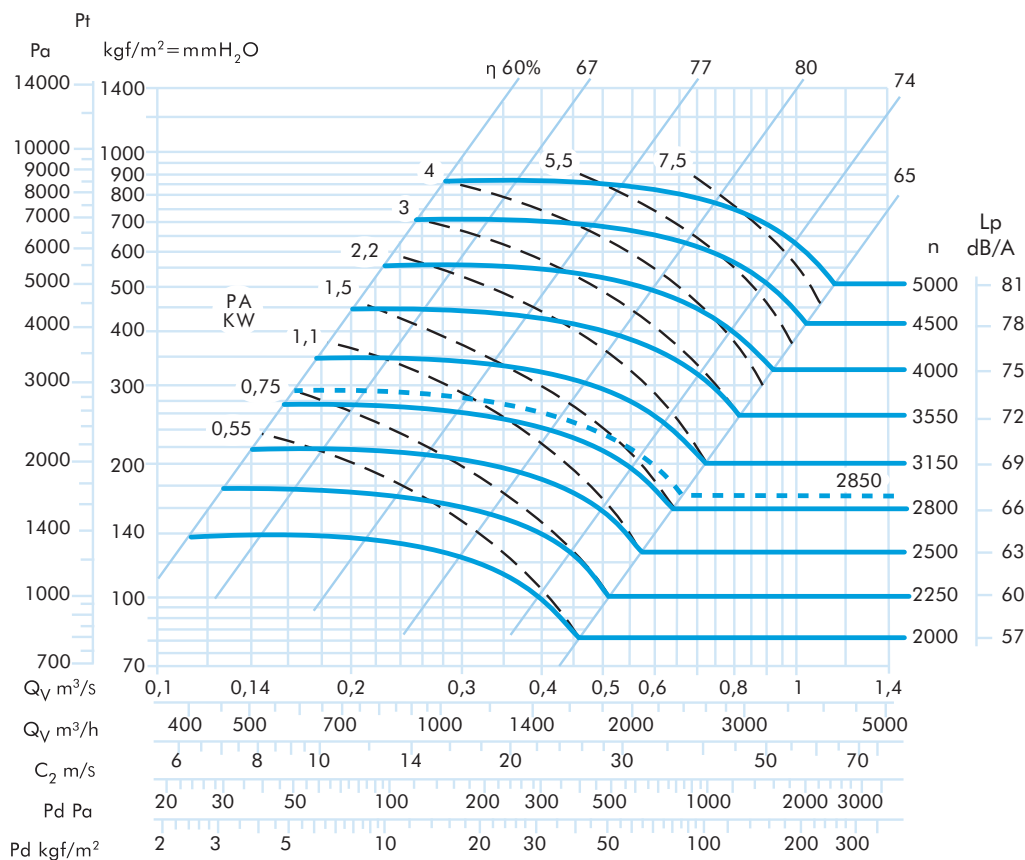

AAZVM 450

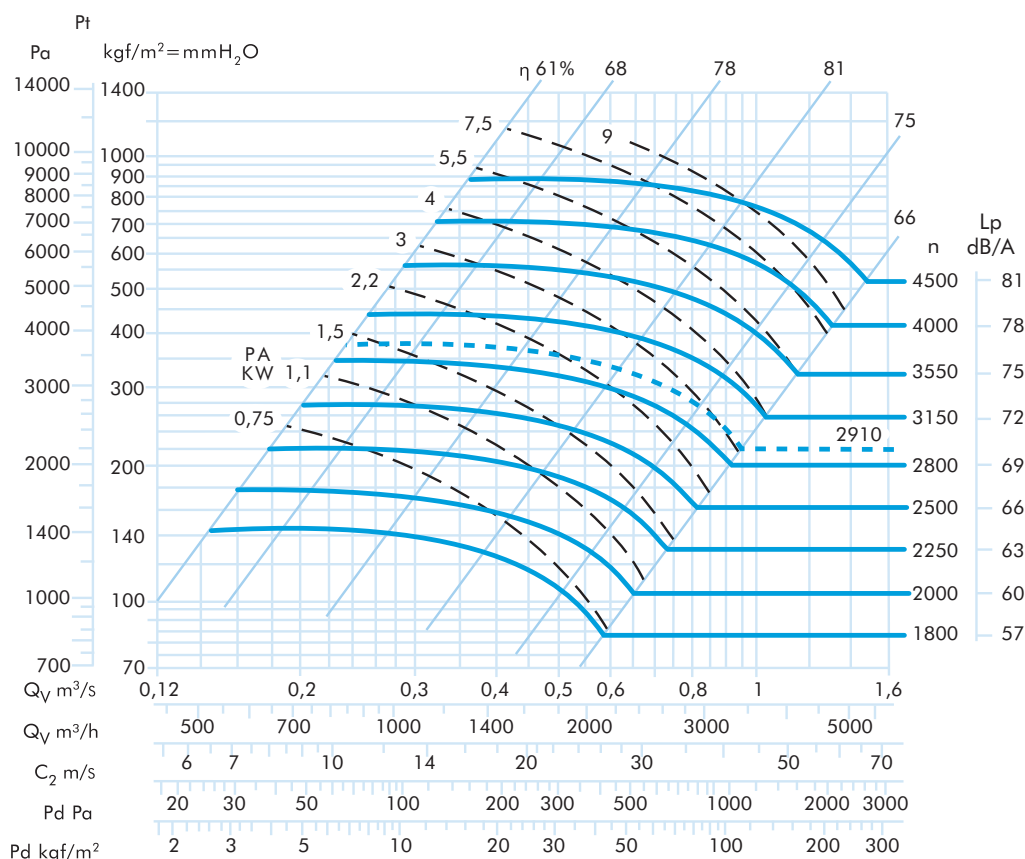

VENTILADORES ALTA PRESIÓN
HIGH PRESSURE FANS
VENTILATEURS HAUTE PRESSION
HOCHDRUCK-RADIALVENTILATOREN

AAZVM

AAZVM 500

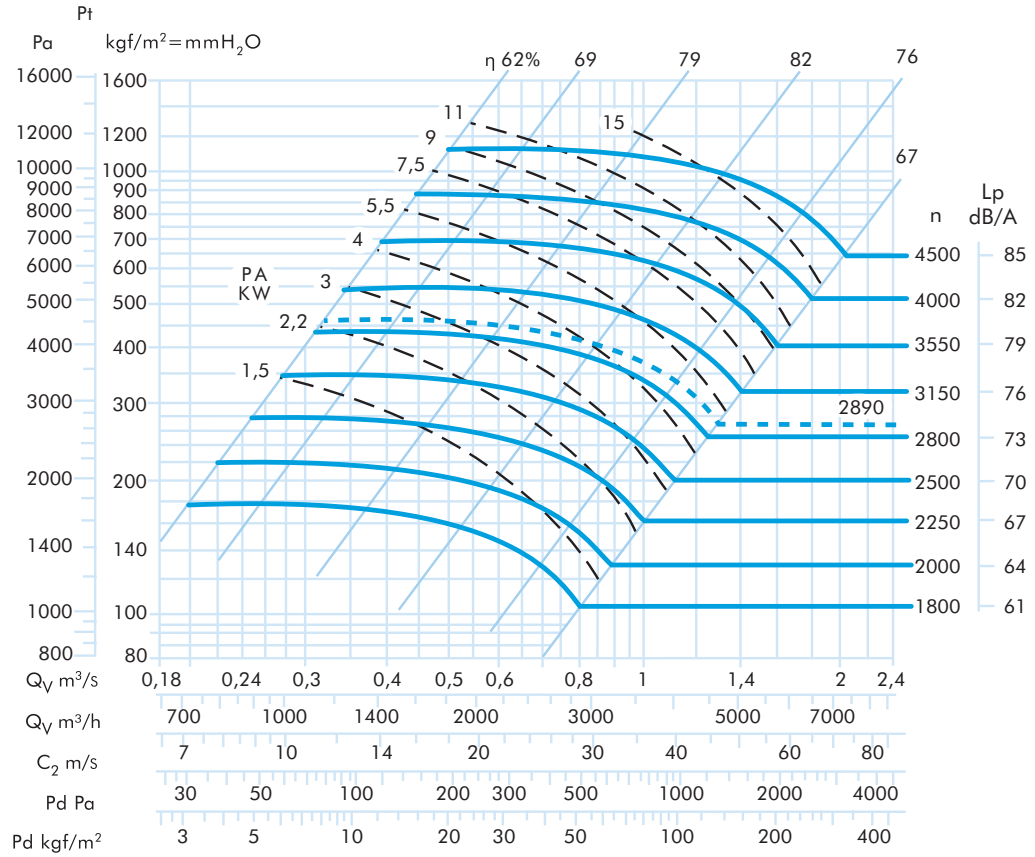

AAZVM 560

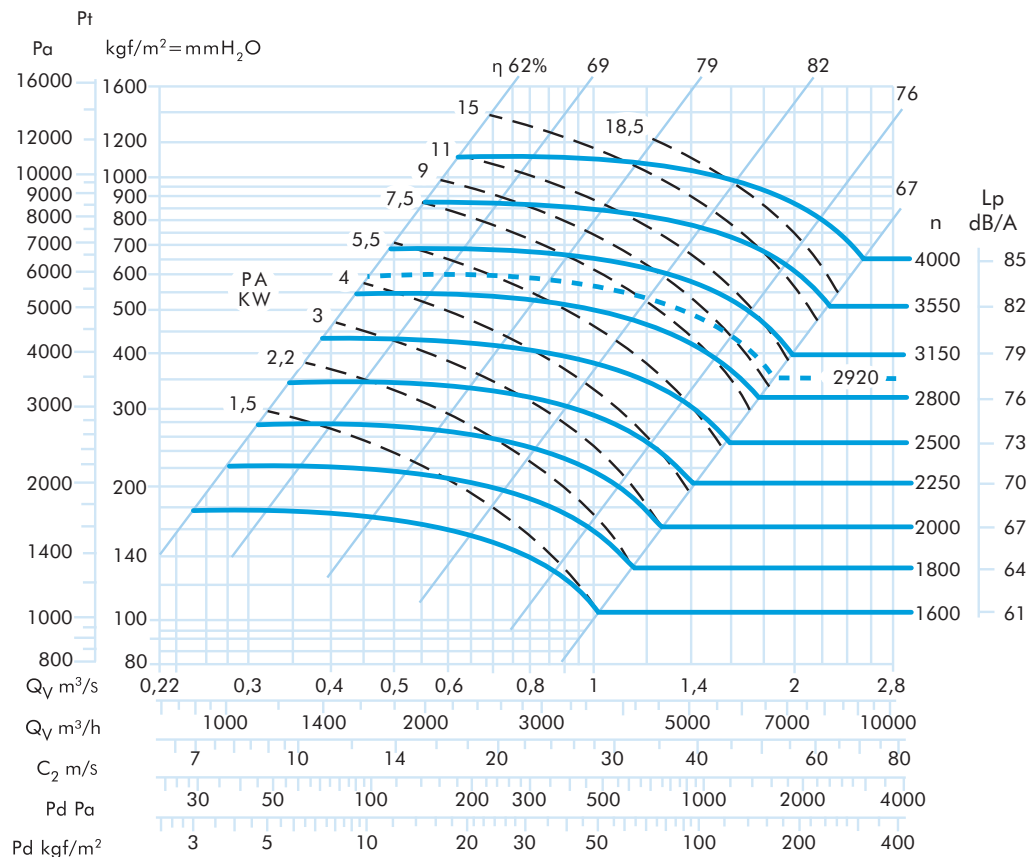

AAZVM

AAZVM 630

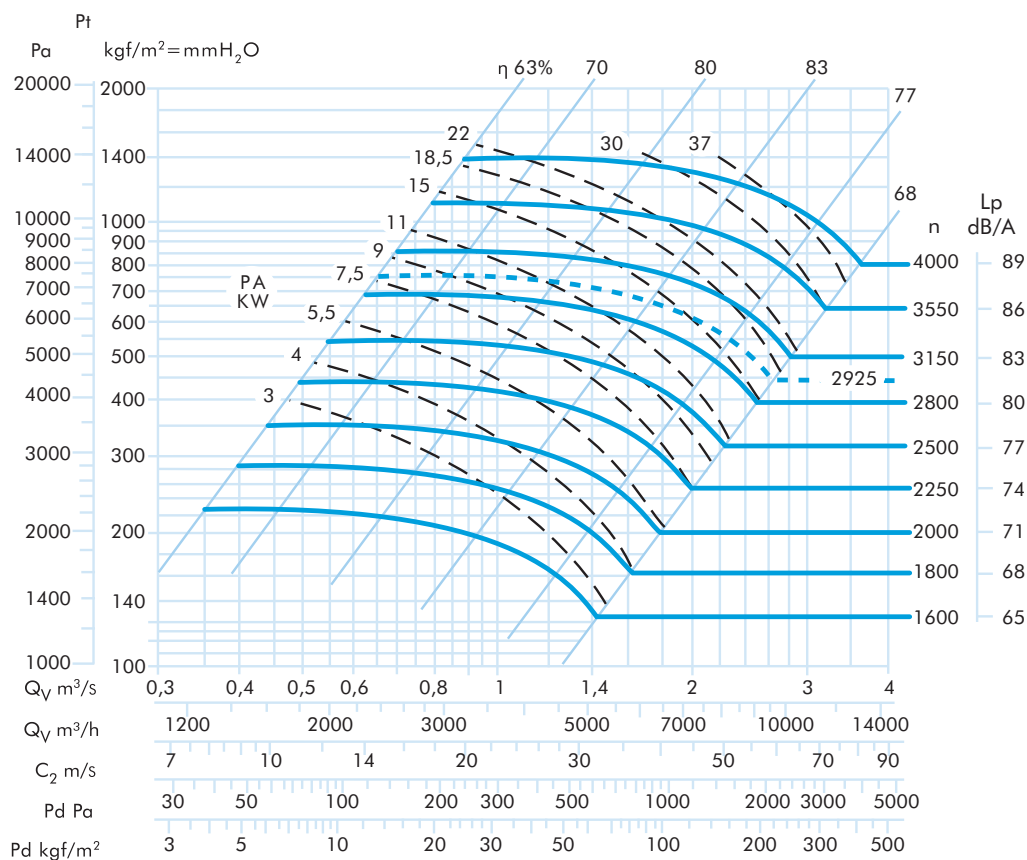

AAZVM 710

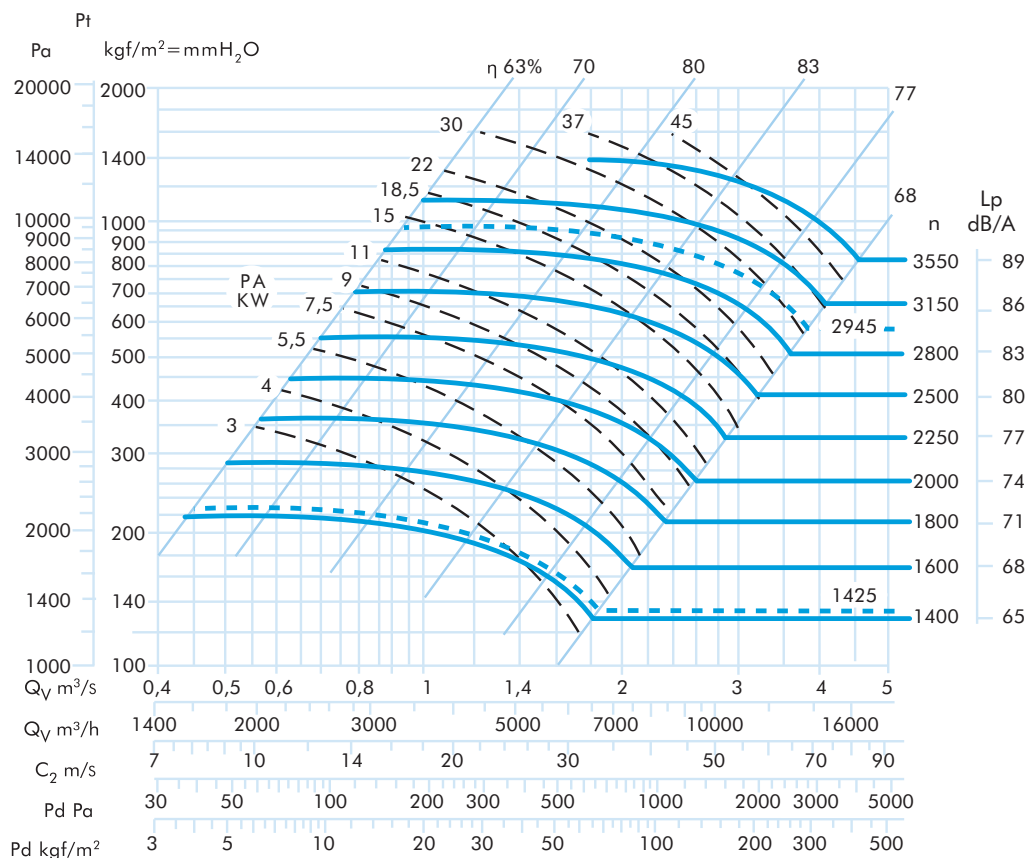

VENTILADORES ALTA PRESIÓN
HIGH PRESSURE FANS
VENTILATEURS HAUTE PRESSION
HOCHDRUCK-RADIALVENTILATOREN

AAZVM

AAZVM 800

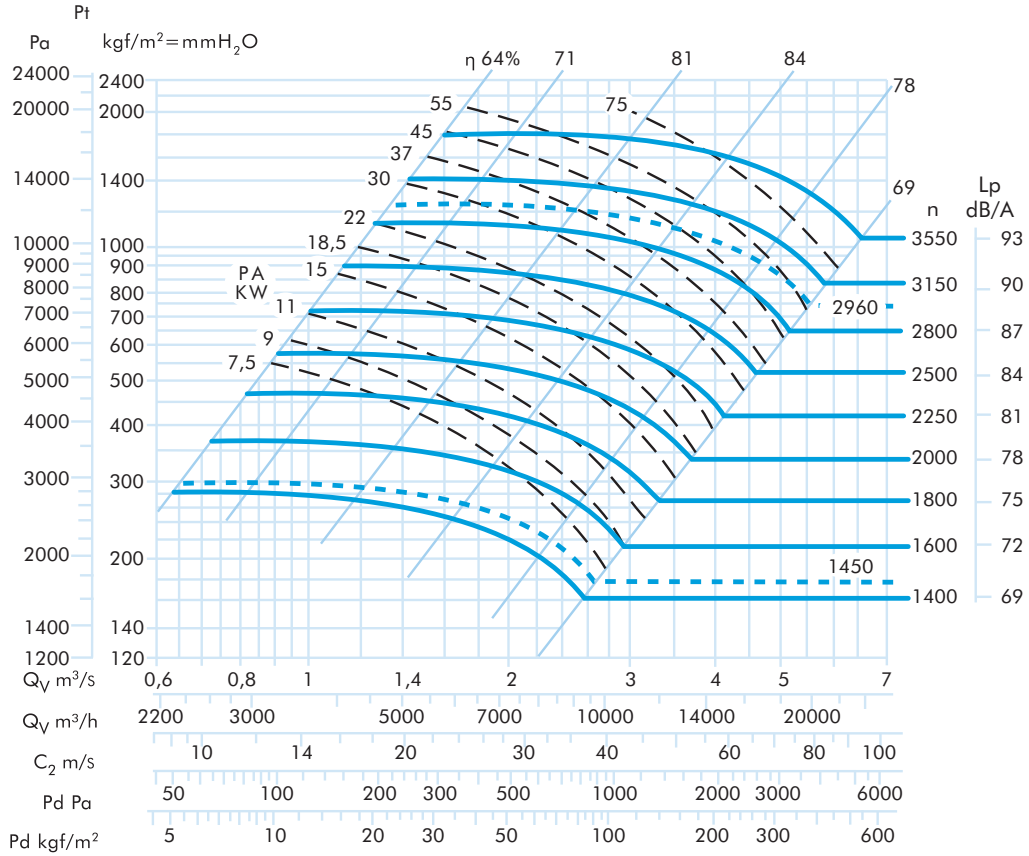

AAZVM 900

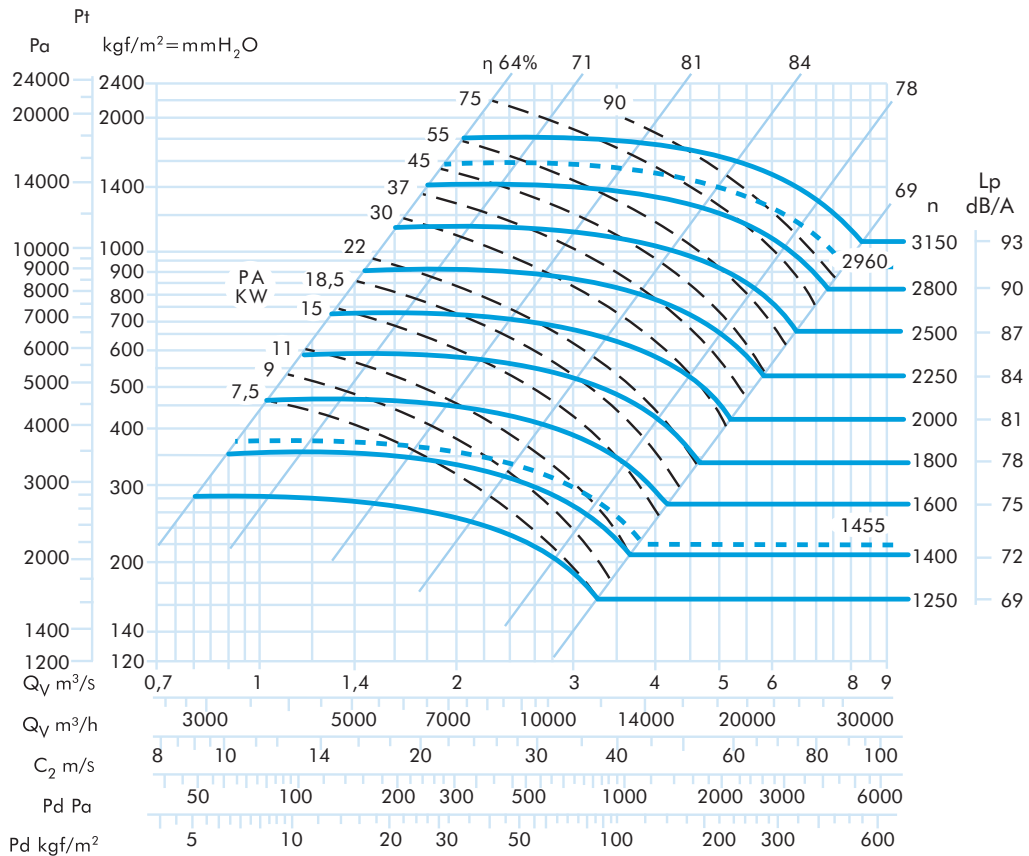

AAZVM

AAZVM 1000

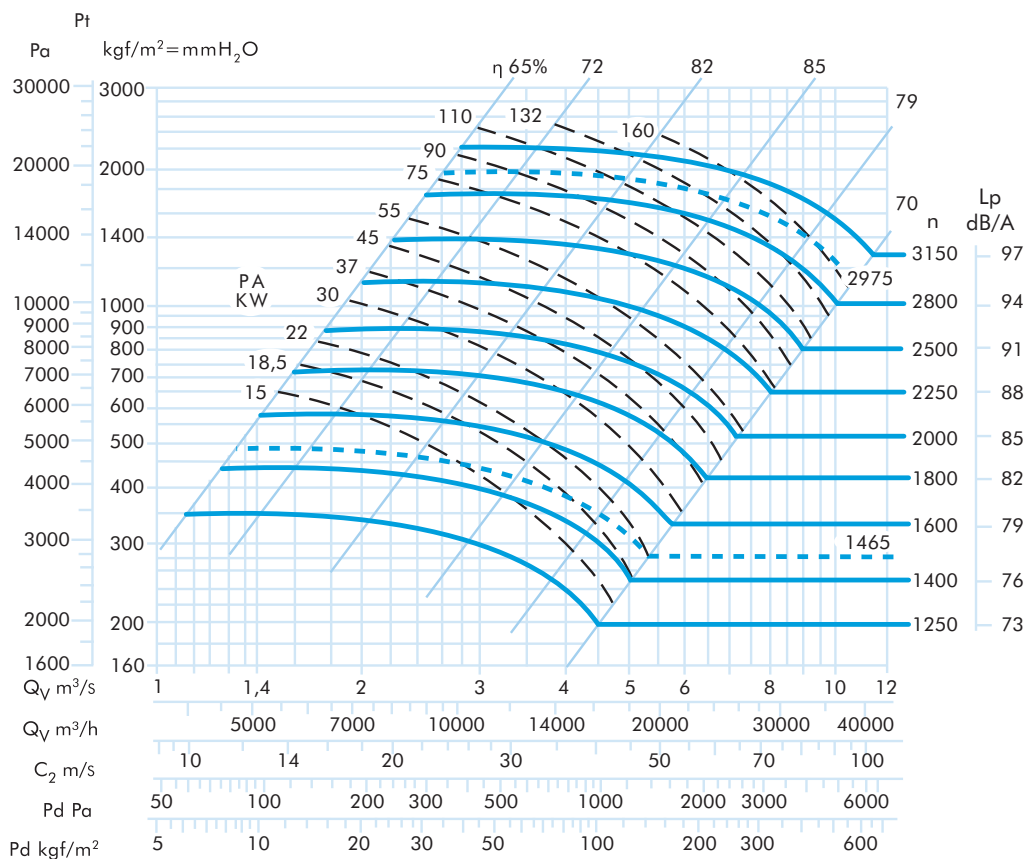

AAZVM 1120

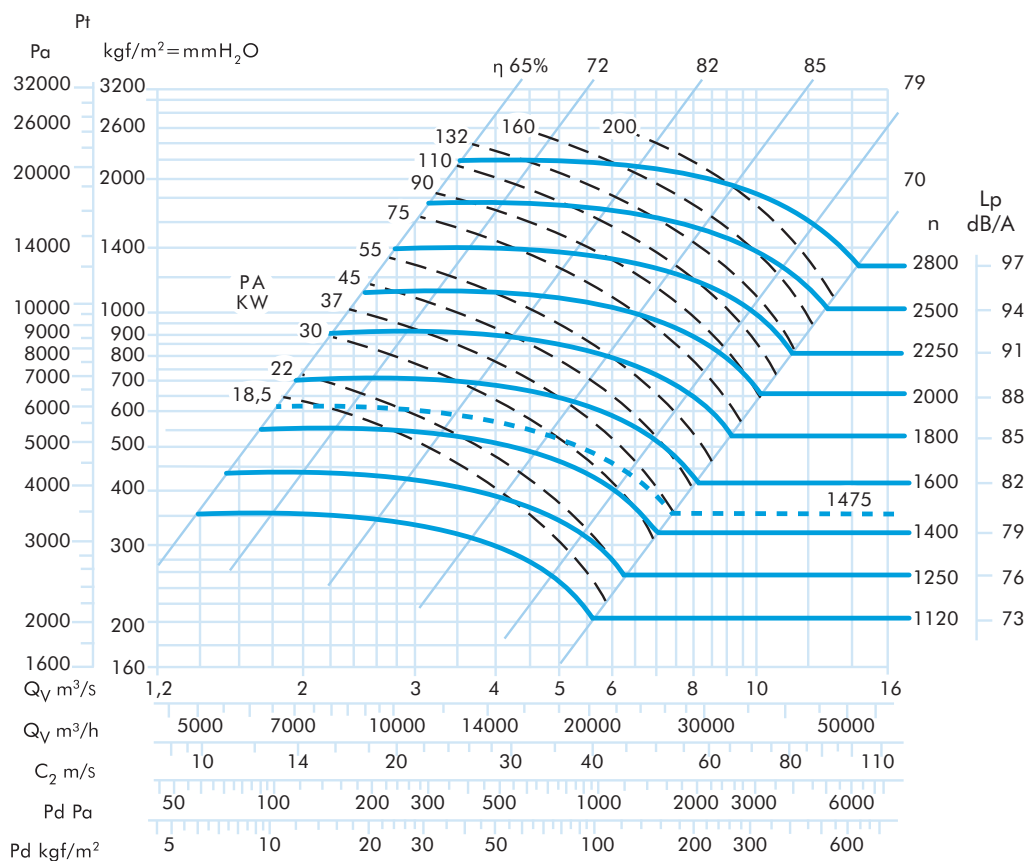

AAZVM 1250

