

Rectangular



Content – Rectangular

Duct



LKR 7

Bends



LBR 8



LBXR 9

S-bend



LBSR 10

Taper



LDR 11

Rect-to-round transition



LORU 12

Collars



LAR 13



LPSR 14

T-piece



LTTT 15

End cover



LEPR 16

Rectangular joint system



Flange profile RJFPC3 17



Corner RJCL 18



Bolt clamp RJBC 19



Slide profile RJSP 19



Bolt M6S, M6SF 19



Nut M6M, M6MF 19



Sealing moulding RJSM 19



Rod RDR 20



Rod bolt RDRB 20



Rod washer RDRW 20



Rod dowel RDRD 20











Rod cross RDRC 21



Vane fastener RDVF 22

Content – Rectangular

Joining parts	
	Joining profile LS 1 23
	Joining profile LS-2 23
	Joining profile LS 31 23
	Joining profile LS 3 23
	Joining profile LS 4 23
	Joining profile LS 5 23
<hr/>	
Regulating damper	See chapter Dampers & Measure units LKSR 303
	
<hr/>	
Access doors	See chapter Access doors
	IPLR 610
	IPF 613
	IPRD 614
	IPL 615
	LKCR 616

General

Some products might differ slightly from country to country. Please contact your local store for correct information. Rectangular consists of rectangular ducts, fittings and silencers with dimensions in accordance with SS-EN 1505 when not otherwise specified. The duct system fulfils tightness class C and pressure class 2 according to EN 1507:2006. All fittings and ducts are made of hot-dip galvanized steel sheet Z 275. If higher corrosion protection is needed, alu-zinc or stainless steel can be used.

A joining profile is mounted at the end of every fitting and duct. A common slide profile LS-3 or bolt clamps and a seal moulding, RJSM is needed to join components. So pre-cut mouldings and an adequate length of seal moulding are supplied in each delivery. Seals are made from temperature resistant polythene. Recommended temperature range is -70 to +80°C.

Support distances of ducts and components must never exceed 2400 mm for any dimension. Nor may there be more than one joint between two supports. The support must be located max. 500 mm from a joint.

Non-standard ducts and duct components can be tendered on request. Please enclose a dimensioned sketch if possible.

Tightness

Ducts and fittings fulfil tightness class C. This only applies on condition that the products are installed in accordance with the installation instruction.

Please refer to page 38–39 for more information about sealing classes and official requirements.

Strength

Standard ducts and duct components can withstand positive of 1000 Pa and negative pressures of -750 Pa.

The ducts are manufactured to fulfil the requirements of EN 1507:2006. This means that when the duct is submitted to the maximum pressure of relevant pressure class than

- the duct slide doesn't bulge or cave more than the smallest value of 3% of its width or 30 mm
- the joint between two products doesn't bulge or cave more than 1/250-part of the longest side width.

Larger ducts and fittings are reinforced by hat-shaped profiles and rods.

Dimensions and weights

The "I"-measures given in the tables are the overall installation dimensions of products. The following tolerances apply, depending on duct or fitting dimensions.

a and b are the internal duct or fitting dimensions.

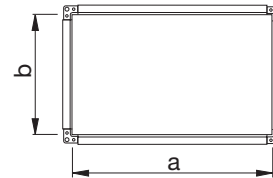

Tolerances for dimensions a and b

when $a + b \leq 1200$: +0 mm

when $a + b > 1200$: +0 mm

Tolerances for "I"-measures ± 5 mm

Hydraulic diameter d_h

The diameter of a circular duct which gives the same pressure drop at the same air velocity as in the rectangular duct.

$$d_h = \frac{4 \cdot A_c}{O} = \frac{2 \cdot a \cdot b}{a + b}$$

Equivalent diameter d_e

The diameter of a circular duct which gives the same pressure drop at the same air flow as in the rectangular duct.

Insulated ducts

Insulated ducts can be made in the following designs:

- Internally condensation and heat insulated with a surface of woven glasfiber Lindtec®
- Internally insulated, clad with solid sheet metal
- Internally insulated, clad with perforated sheet metal
- Internal fire protection insulation 50 and 100 mm

The insulation is a type approved insulation material (according to Swedish regulation) TG 1221 or TG 2706/92:

Reaction to fire, class A2,s1-d0

Cannot be used in oily or greasy environment and can only be cleaned with a plastic brush.

General

Technical data for standard sizes

Cross-sectional area, A_c [m²]

b \ a	200	250	300	400	500	600	800	1000	1200	1400	1600	1800	2000
100	0,02	0,03	0,03	0,04									
150	0,03	0,04	0,05	0,06	0,08	0,09							
200	0,04	0,05	0,06	0,08	0,10	0,12	0,16						
250		0,06	0,08	0,10	0,13	0,15	0,20	0,25					
300			0,09	0,12	0,15	0,18	0,24	0,30	0,36				
400				0,16	0,20	0,24	0,32	0,40	0,48	0,56	0,64		
500					0,25	0,30	0,40	0,50	0,60	0,70	0,80	0,90	1,00
600						0,36	0,48	0,60	0,72	0,84	0,96	1,08	1,20
800							0,64	0,80	0,96	1,12	1,28	1,44	1,60
1000								1,00	1,20	1,40	1,60	1,80	2,00
1200									1,44	1,68	1,92	2,16	2,40
1400										1,96	2,24	2,52	2,80
1600											2,56	2,88	3,20
1800												3,24	3,60
2000													4,00

$$A_c = a \times b$$

Circumference, O [m]

b \ a	200	250	300	400	500	600	800	1000	1200	1400	1600	1800	2000
100	0,6	0,7	0,8	1,0									
150	0,7	0,8	0,9	1,1	1,3	1,5							
200	0,8	0,9	1,0	1,2	1,4	1,6	2,0						
250		1,0	1,1	1,3	1,5	1,7	2,1	2,5					
300			1,2	1,4	1,6	1,8	2,2	2,6	3,0				
400				1,6	1,8	2,0	2,4	2,8	3,2	3,6	4,0		
500					2,0	2,2	2,6	3,0	3,4	3,8	4,2	4,6	5,0
600						2,4	2,8	3,2	3,6	4,0	4,4	4,8	5,2
800							3,2	3,6	4,0	4,4	4,8	5,2	5,6
1000								4,0	4,4	4,8	5,2	5,6	6,0
1200									4,8	5,2	5,6	6,0	6,4
1400										5,6	6,0	6,4	6,8
1600											6,4	6,8	7,2
1800												7,2	7,6
2000													8,0

$$O = 2 \times (a + b)$$

Hydraulic diameter, d_h [mm]

b \ a	200	250	300	400	500	600	800	1000	1200	1400	1600	1800	2000
100	133	143	150	160									
150	171	188	200	218	231	240							
200	200	222	240	267	286	300	320						
250		250	273	308	333	353	381	400					
300			300	343	375	400	436	462	480				
400				400	444	480	533	571	600	622	640		
500					500	545	615	667	706	737	762	783	800
600						600	686	750	800	840	873	900	923
800							800	889	960	1018	1067	1108	1143
1000								1000	1091	1167	1231	1286	1333
1200									1200	1292	1371	1440	1500
1400										1400	1493	1575	1647
1600											1600	1694	1778
1800												1800	1895
2000													2000

$$d_h = 4 \times A_c / O = 2 \times a \times b / (a + b)$$

General

Equivalent diameter, d_e [mm]

b \ a	200	250	300	400	500	600	800	1000	1200	1400	1600	1800	2000
100	152	169	183	207									
150	189	210	229	260	287	310							
200	219	244	267	305	337	366	414						
250		274	299	344	381	414	470	518					
300			328	378	421	458	521	575	621				
400				438	489	534	610	675	732	783	829		
500					547	599	688	763	829	888	941	991	1036
600						657	757	842	916	982	1043	1098	1150
800							876	978	1068	1148	1221	1289	1351
1000								1095	1199	1292	1376	1454	1527
1200									1314	1419	1514	1602	1684
1400										1534	1639	1736	1826
1600											1753	1858	1957
1800												1972	2078
2000													2191

$$d_e = 2 \times b \times (\pi^{2-n} \times (1 + a/b)^{1+n} / (a/b)^3)^{1/(n-5)}$$

where $n = 1 / (1,05 \times \log(\text{Re}) - 0,45)$

where $\text{Re} = v_m \times d_h / \nu$

where $v_m = 5 \text{ m/s}$

and $\nu = 0,000\ 000\ 101\ 312 \times t + 0,010\ 013\ 001\ 375\ 72$

where $t = 20^\circ\text{C}$

Specific weight, m_l [kg/m]

b \ a	200	250	300	400	500	600	800	1000	1200	1400	1600	1800	2000
100	4	5	6	7									
150	5	6	6	8	9	11							
200	6	6	7	8	10	11	15						
250		7	8	9	11	12	16	19					
300			8	10	11	13	16	19	22				
400				11	13	14	18	21	24	27	33		
500					14	15	19	22	25	28	35	38	41
600						17	21	24	27	30	36	40	42
800							25	28	31	34	41	44	45
1000								31	34	37	44	47	49
1200									37	40	47	50	52
1400										43	50	53	55
1600											58	61	62
1800												65	65
2000													69

Duct

LKR



Dimensions

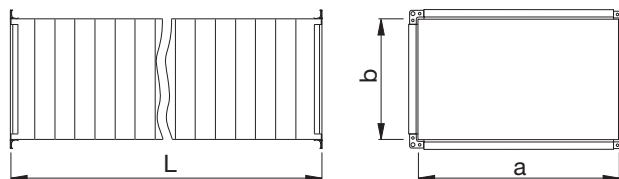

Description

Straight duct, stiffened with transverse trapezoid corrugations, which reduces the risk of noise generation. Larger dimensions have stiffening profiles and/or internal rods. Installation height of these profiles is 23 mm.

Ducts are normally supplied with a strong joining profile RJFP 20 or RJFP 30 at each end, but can also be supplied as a flexible piece, where the joining profile on one end is not fixed. Also available with an end cover fixed by joining profiles.

Ordering example

	LKR	500	300	1500	1
Product					
Largest side	a				
Smallest side	b				
Length	L				
RJFP-joint at both ends		1			
RJFP-joint at one end		2			
Loose joint included.					
RJFP-joint at one end		3			
End cover on joining profiles at other end.					
End cover on joining profiles at both ends.		4			
RJFP-joint at one end		5			
No loose joint included.					

Bend

LBR



Description

Bend with sharp outer corner, stiffened with trapezoid corrugation. The bend is delivered with 90° or 45° angles and joining profile RJFP at both ends. Other leg lengths and angles can also be ordered. Standard design $l_1 = l_2 = 125$ mm.

Dimensions

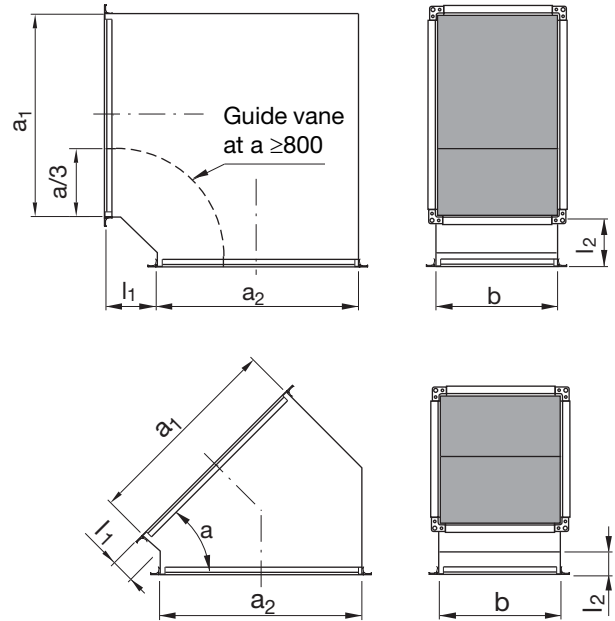

Ordering example

	LBR	500	300	500	90	125	125
Product							
Form side	a_1						
Curved side	b						
Form side	a_2						
Angle	α						
Leg length	l_1						
Leg length	l_2						

Bend

LBXR

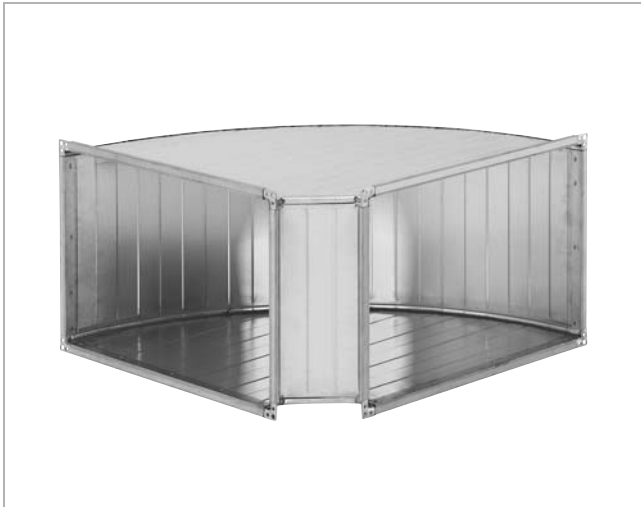

Description

Bend with rounded outer corner, stiffened with trapezoid corrugations.

The bend is delivered with 90° or 45° angles and joining profiles type RJFP at both ends. Other leg lengths and angles can also be ordered.

Standard design $l_1 = l_2 = 125$ mm.

Dimensions

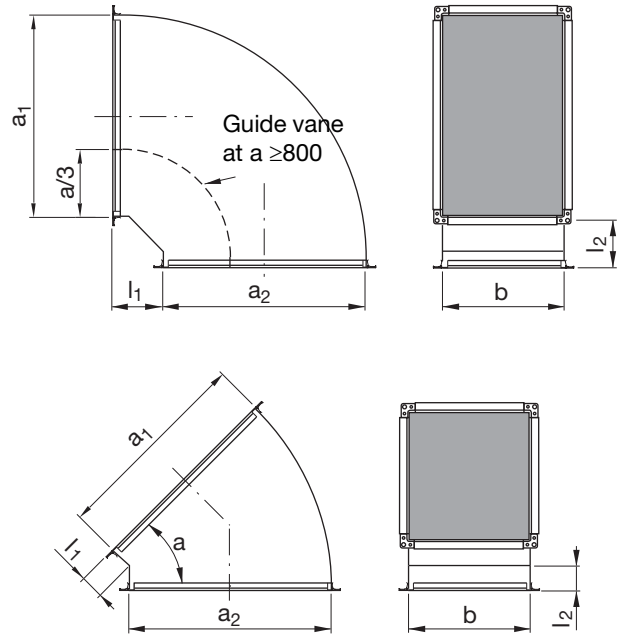

Ordering example

	LBXR	500	300	500	90	125	125
Product							
Form side	a_1						
Curved side	b						
Form side	a_2						
Angle	α						
Leg length	l_1						
Leg length	l_2						

S-bend



Description

Used for deflections of the duct system, for example where ducts cross.

Has a joining profile type RJFP at both ends, and is stiffened by trapezoid corrugations.

A special relationship is needed between the a-dimension, fall f and length l for the LBSR to retain its cross-sectional area and not restrict the air flow. For this reason, standard lengths and standard drops have been prepared.

Ordering example

Product	LBSR	300	600	300	400
Form side	a				
Curved side	b				
Fall	f				
Length	l				

LBSR

Dimensions

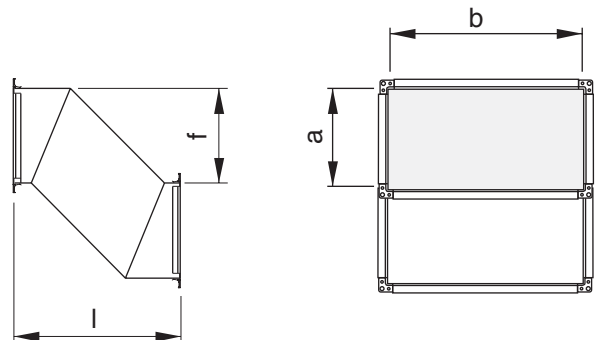

a mm	l std mm	f std mm
100	400	300
150	400	300
200	400	300
250	400	300
300	500	300
350	500	300
400	600	400
450	600	400
500	600	400
600	700	400
700	800	500
800	900	500
900	1000	500
1000	1100	500
1100	1200	500
1200	1300	500
1300	1400	500
1400	1500	500
1500	1600	500
1600	1700	500
1800	1900	500
2000	2100	500

Taper

LDR



Description

The taper is used as transition between different duct dimensions. The larger dimensions are available with offsets as in the coded sketches.

Dimension changes have a joining profile type RJFP at both ends, and are stiffened by trapezoid corrugations.

Measures e and h only need to be given for alternative 6. Negative values for e, for example, mean that e is outside side a.

Dimensions

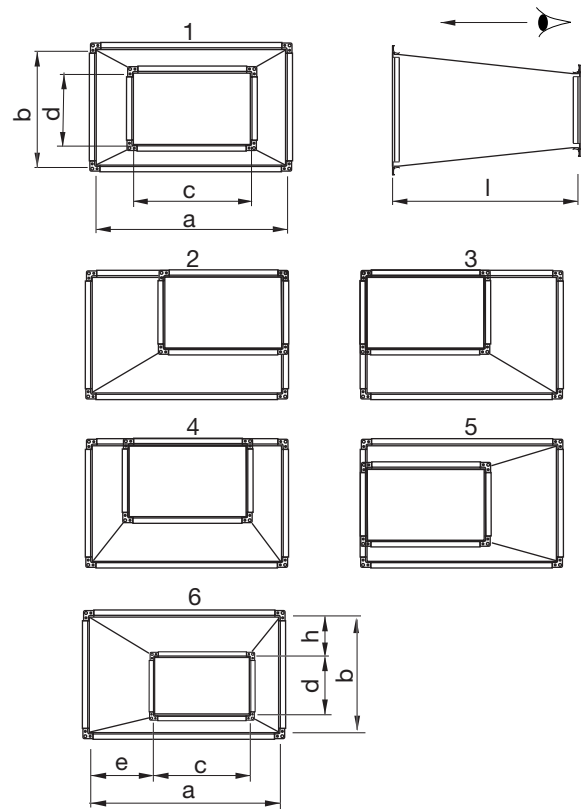

Ordering example

	LDR	500	300	300	200	1	450
Product									
Large end a									
Large end b									
Small end c									
Small end d									
The alternative displacements are seen from the cxd end									
Length l									
Displacement e (Only at alternative 6.)									
Displacement h (Only at alternative 6.)									

a mm	l std mm
100	300
150	300
200	300
250	300
300	300
350	300
400	450
450	450
500	450
600	450
700	450
800	600
900	600
1000	600
1100	600
1200	600
1300	600
1400	600
1500	600
1600	600
1800	600
2000	600

Rect-to-round transition

LORU



Dimensions

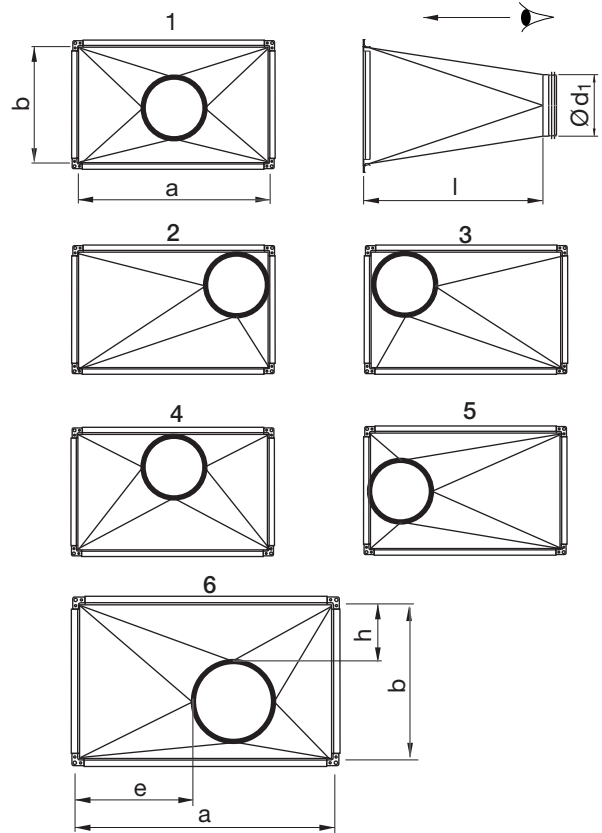

Description

Rect-to-round transition are used between rectangular and circular ducts. The rectangular connection has joining profiles type RJFP and the circular connection has Safe seal. The rectangular connection is available with offsets as in the coded sketches.

Measures e and h only need to be given for alternative 6. Negative values for e, for example, mean that e is outside side a.

The Rect-to-round transition LORU can also be manufactured with other designs of the circular connection. It then changes name as follows:

- LORNP: Transition with male coupling (without gasket)
- LORMF: Transition with female coupling
- LORFL: Transition with flange coupling

Ordering example

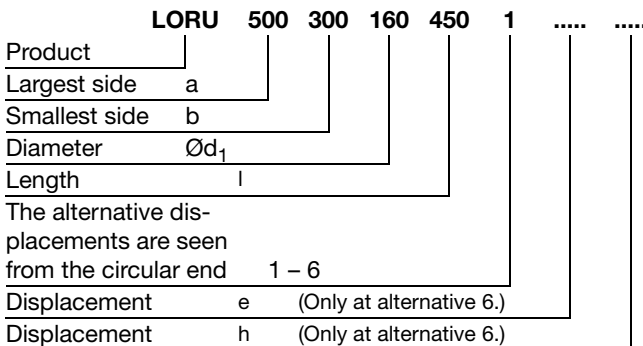

a mm	l std mm
100	300
150	300
200	300
250	300
300	300
350	300
400	450
450	450
500	450
600	450
700	450
800	600
900	600
1000	600
1100	600
1200	600
1300	600
1400	600
1500	600
1600	600
1800	600
2000	600

Collar

LAR



Description

The collar is used for connection to rectangular duct. The smaller joint end is provided with joining profiles type RJFP. The larger one has an edge, for fixing with blind rivets or self-tapping screws, but can also be given a folding tab to facilitate assembly.

Dimensions

Sloping design: FAS

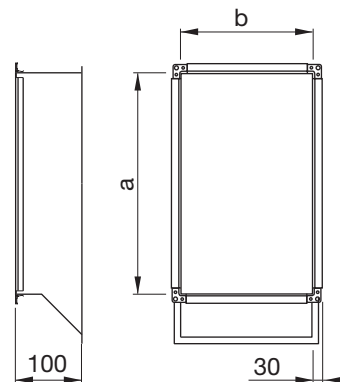

Straight design: RAK

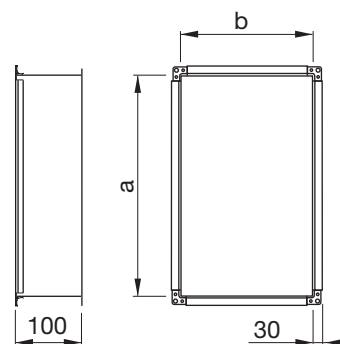

Ordering example

		LAR	500	300	100	FAS
Product						
Form side	a					
Curved side	b					
Length						
Design	sloping	FAS *				
	straight	RAK				

*FAS can only be selected if the length is 50 mm or more.

Collar on circular duct

LPSR



Dimensions

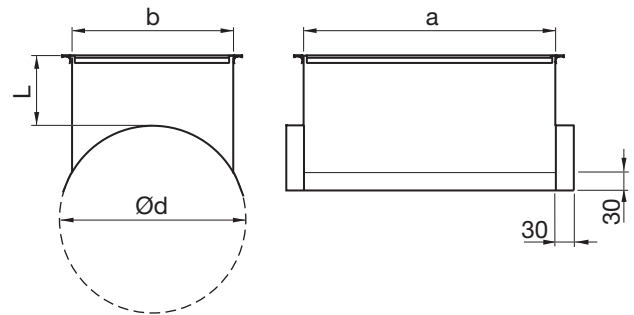

Description

The collar is used for connection to circular duct. The rectangular end is provided with joining profiles type RJFP. The rounded end has an edge, for fixing with blind rivets or self-tapping screws.

Other lengths can also be supplied.

Ordering example

Product	LPSR	600	300	400	100
Side	a				
Side	b				
Diameter	Ød				
Length					

T-piece

LTTR



Dimensions

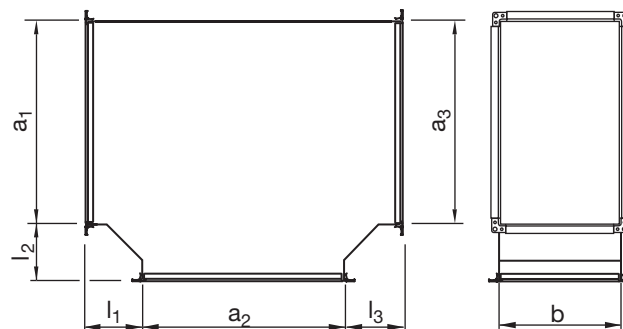

Description

A T-piece which is provided with joining profiles type RJFP and is stiffened with trapezoid corrugations.
 Standard design $l_1 = l_2 = l_3 = 125$ mm.
 Other leg lengths can also be supplied.

Ordering example

	LTTR	600	800	600	400	125	125	125
Product								
Side a_1								
Side a_2								
Side a_3								
Side b								
Leg length l_1								
Leg length l_2								
Leg length l_3								

End cover

LEPR



Dimensions

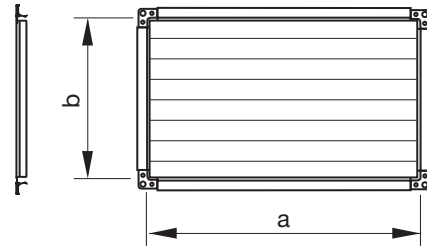

Description

Used as end cover in duct.

The edges are equipped with joining profiles type RJFP.

The end cover is stiffened with trapezoid corrugations.

Ordering example

Product	LEPR	500	300
Largest side	a		
Smallest side	b		

Rectangular joint system

The joint system is strong, airtight and easy to install.

- Flange profiles
- Corners
- Flange profile fasteners
- Corner fasteners
- Seal moulding



Flange profiles

RJFPC3 Rectangular Joint Flange Profil comes in three sizes, different sheet steel thicknesses, with and without sealant.



Dimensions

Code	Dim	Length	Material	Type	Thickness
RJFPC3	20	5000	GALV		0,7
RJFPC3	20	5000	GALV	SEAL	0,7
RJFPC3	30	5000	GALV		0,8
RJFPC3	30	5000	GALV	SEAL	0,8
RJFPC3	40	5000	GALV		1,25
RJFPC3	20	5000	4404		0,8
RJFPC3	40	2500	4404		1,22

Ordering example

	RJFPC3	20	5000	GALV	0,7
Product					
Dimension					
Length					
Material					
Thickness					

RJFPC3 20



RJFPC3 30



RJFPC3 40



Rectangular joint system

Corners

RJCL 20

The corner is constructed to fit the flange profile RJFP 20.



Length 66 is to be used when the side of the duct is very small. Up to 100 mm.



Length 76 is to be used in all normal cases where the 20 profile is used.

RJCL 30

The corner is constructed to fit the flange profile RJFP 30.



RJCL 40

The corner is constructed to fit the flange profile RJFP 40.



Dimensions

Code	Dim	Length	Material	Thickness
RJCL	20	66	GALV	2,5
RJCL	20	76	GALV	2,5
RJCL	30	103	GALV	3,0
RJCL	40	123	GALV	3,7
RJCL	20	76	4404	2,5
RJCL	30	103	4404	3,7

Ordering example

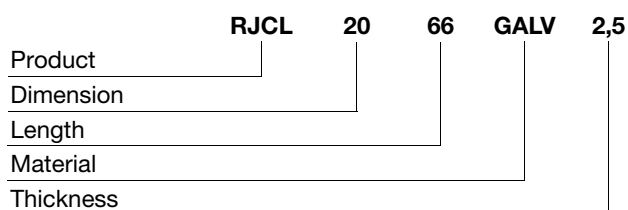

Rectangular joint system

Flange profile fasteners

RJBC

Rectangular Joint Bolt Clamp



Clamp which is fastened over the flanges of the two rectangular ducts to fasten them to each other.

The clamp is easy to use where there is sufficient space to fasten the clamp.

RJSP

Rectangular Joint Slide Profile

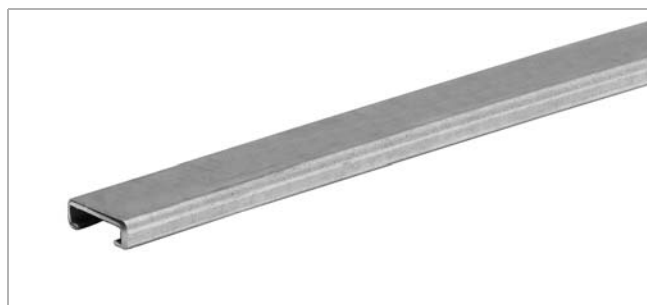

The slide profile does not demand space above the profile, but there has to be space at the side of the duct.

Dimensions

Code	Dim	Length	Material	Thickness
RJBC			GALV	2,5
RJBC			4404	2,5
RJSP		5000	4404	1
RJSP		5000	GALV	1,2
M6S, M6SF	8	25	GALV	
M6S, M6SF	10	25	GALV	
M6M, M6MF	8		GALV	
M6M, M6MF	10		GALV	
RJSM	9	10000	PE	4
RJSM	12	10000	PE	4

Ordering example

	RJBC	GALV	2,5
Product			
Material			
Thickness			

Corner fasteners

The M8 bolt and nut is to be used with all the RJCL 20 corners. The M10 bolt and nut is to be used with RJCL 30 and 40 corners.

M6S, M6SF

Rectangular Joint Bolt



M6M, M6MF

Rectangular Joint Nut



Seal moulding

RJSM

Rectangular Joint Seal Moulding



The 9 mm seal moulding is to be used with RJFP 20 profile.

The 12 mm seal moulding is to be used with RJFP 30 and 40 profiles.

The 12 mm seal moulding can also be used as flange sealing for FL, see catalogue page for FL for more information.

Rectangular duct stiffeners

The rod is round and together with the crosses and the rod fasteners it will decrease the bulging and caving of the duct.

- Rod
- Rod fasteners
- Rod crosses



Rod

RDR

Rectangular Duct Rod



Dimensions

Code	Dim	Length	Material
RDR		6000	GALV
RDRB	6	40	GALV
RDRW			GALV
RDRD	6		

Ordering example

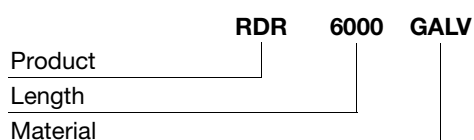

Rod fasteners

RDRB

Rectangular Duct Rod Bolt



RDRW

Rectangular Duct Rod Washer



RDRD

Rectangular Duct Rod Dowel



Rectangular duct stiffeners

Rod crosses

RDRC

Rectangular Duct Rod Cross



The metal cross is used for large ducts.



The plastic cross is used for small ducts.

Dimensions

Code	Material
RDRC	GALV
RDRC	PE

Ordering example

	RDRC	GALV
Product	_____	_____
Material	_____	_____

The vane fasteners are easy to mount and gives a stable and airtight construction.

- Vane fasteners

Vane fasteners

Rectangular Duct Vane Fastener

RDVF



The small Vane Fastener is used for sheet steel thickness 0,75–0,9 mm.



The large Vane Fastener is used for sheet steel thickness 0,75–1,20 mm.

Dimensions

Code	Material	Type
RDVF	GALV	SMAL
RDVF	GALV	LARG

Ordering example

	RDVF	GALV	SMAL
Product			
Material			
Type			

Joining parts

LS

Description

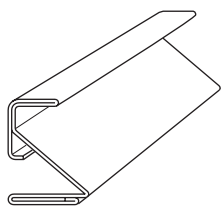

Joining profile LS 1

Joining profile designed to be fixed to the duct by embossing with a special pincers. It is sealed to the duct by special factory-applied seam putty. Profile height is app. 20 mm. Normally supplied in 5 m lengths.

Specific weight: 0,40 kg/m

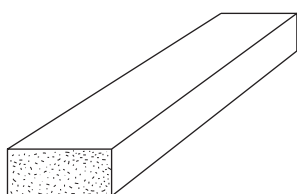

Seal moulding LS-2

The seal moulding is intended to be installed in each joining profile.

Made from polythene foam. Supplied in 10 m coils.

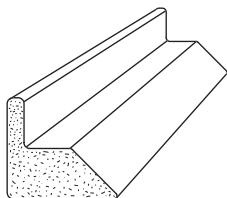

Seal moulding LS 31

The seal moulding is intended to be installed in each joining profile.

Made from polythene foam.

Included as standard with all orders.

Supplied in 250 m in cartons.

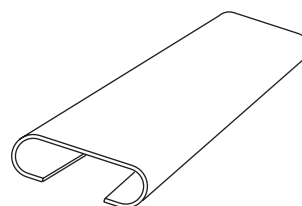

Slide profile LS 3

Used to join two ducts or fittings which both have joining profiles.

Normally supplied in 5 m lengths.

Specific weight: 0,20 kg/m

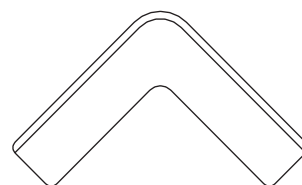

Inner corner LS 4

Used to keep the seal moulding in place and give the ventilation duct stiffness and stability.



Outer corner LS 6

Used outside the slide profile to protect the seal moulding and stiffen the joint. Gives a neat finish.

Other joining methods

If you do not want to fix ducts or duct components together with slide mouldings, as described above, we can meet your needs. You must then specify the particular method of joining you want, in plain language. For example: blind rivet edge 25 mm, flat bar flange to a particular standard, or equivalent.